



SOLAR 24T

The World's Most Versatile Lifting Machine

Model: Solar 24T

Hook Capacity: 5,000 lbs

Fork Capacity: 1,500 lbs

Glazier Capacity: 1,400 lbs

Robot or Jib Capacity: 1,000 lbs

Winch Capacity: 3,000 lbs

Reach: Industry leading reach with below grade capability.

Motor: Propane-powered Kohler PCH740 Power-unit

Weight: 6,000 Lbs + Attachment

Proportional Controls: Electric Joystick for Proportional Lift and Extend. Includes 2-Speed HI/LOW switch for precise slow speed control.

Boom: Base unit, 2 telescoping booms and one manual pull-out boom. Attachments replace pull-out boom.

Hydraulics: Gear Pump with Load Sense Dump.

Rated Load Limiter: Displays rated load and actual load. Stops when rated load is reached. Detects which attachment is installed and automatically adjusts load parameters.

Precise & Efficient Piston Pump

- Load Sensing
- Horsepower Limiting

Adjustable Tracks

- 8" of Vertical Slope Adjustment
- 35.5" Retracted - Single Door
- 52" Max Width for Stability
- No Outriggers Required
- Pick & Carry Full Capacity



Radio Remote Controls

LOAD CAPACITY CHARTS

** MULTIPLE PATENTS PENDING **

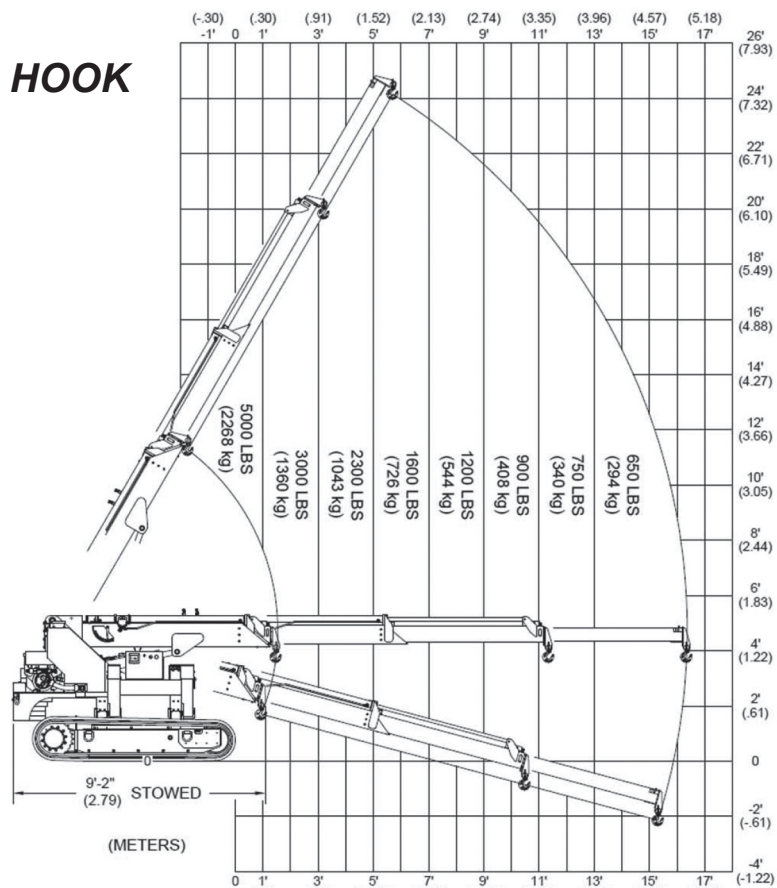

MODEL SOLAR 24T

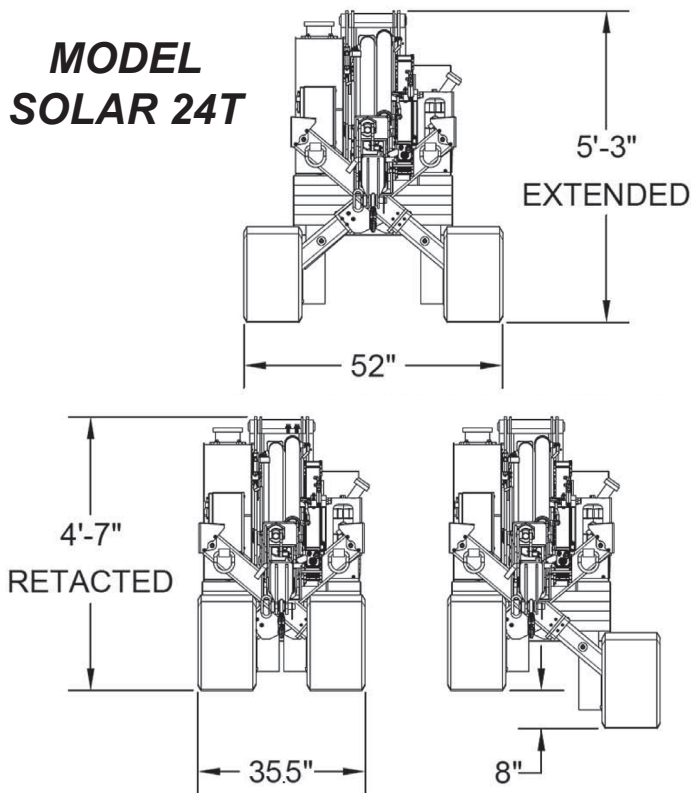

FORK LIFT

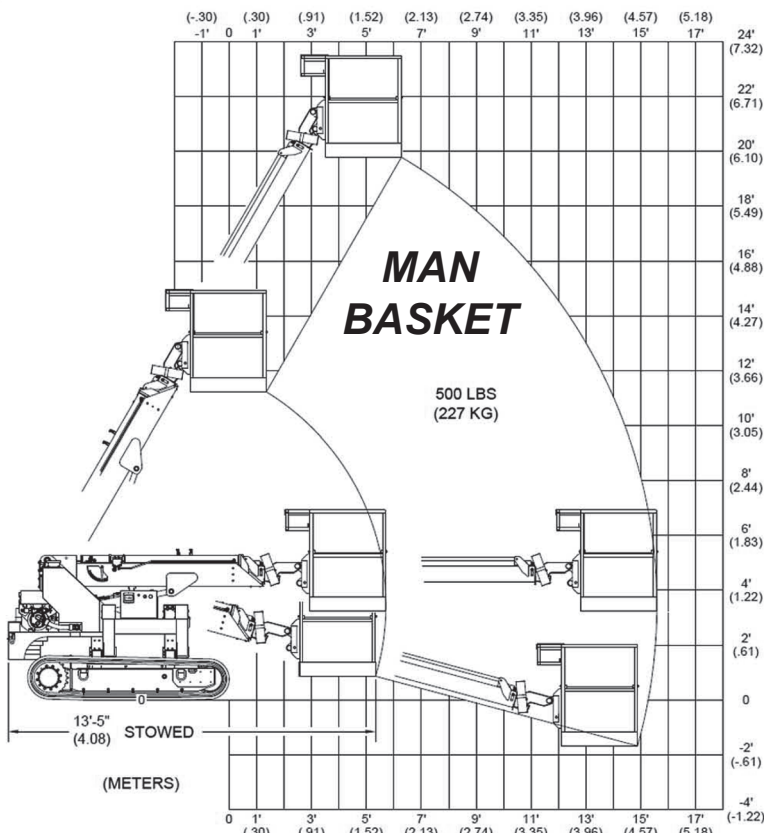
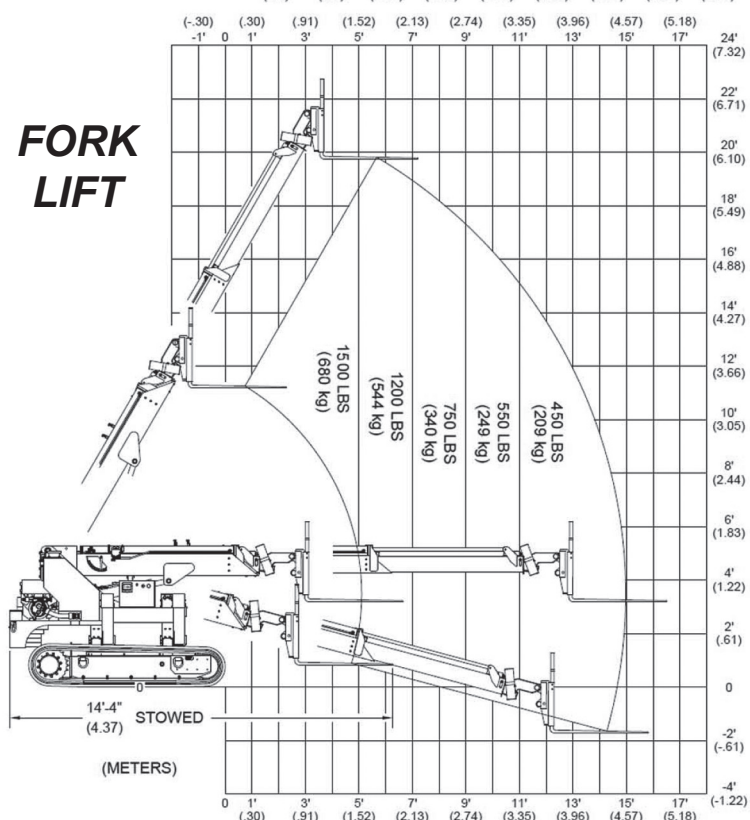

ENGINEERING THE FUTURE OF LIFT EQUIPMENT

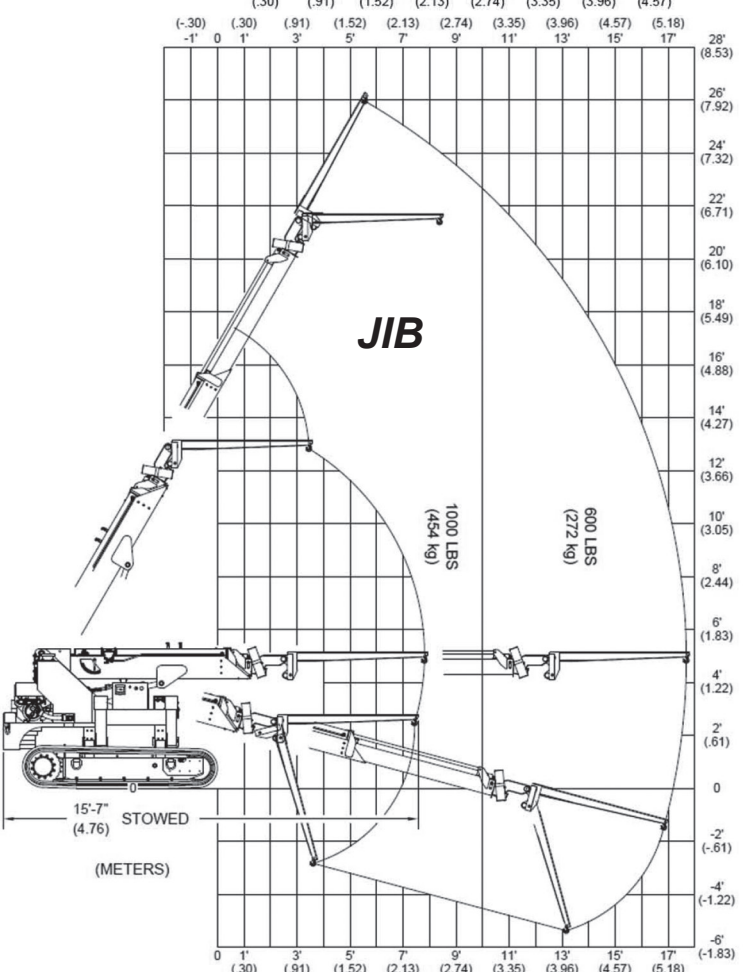
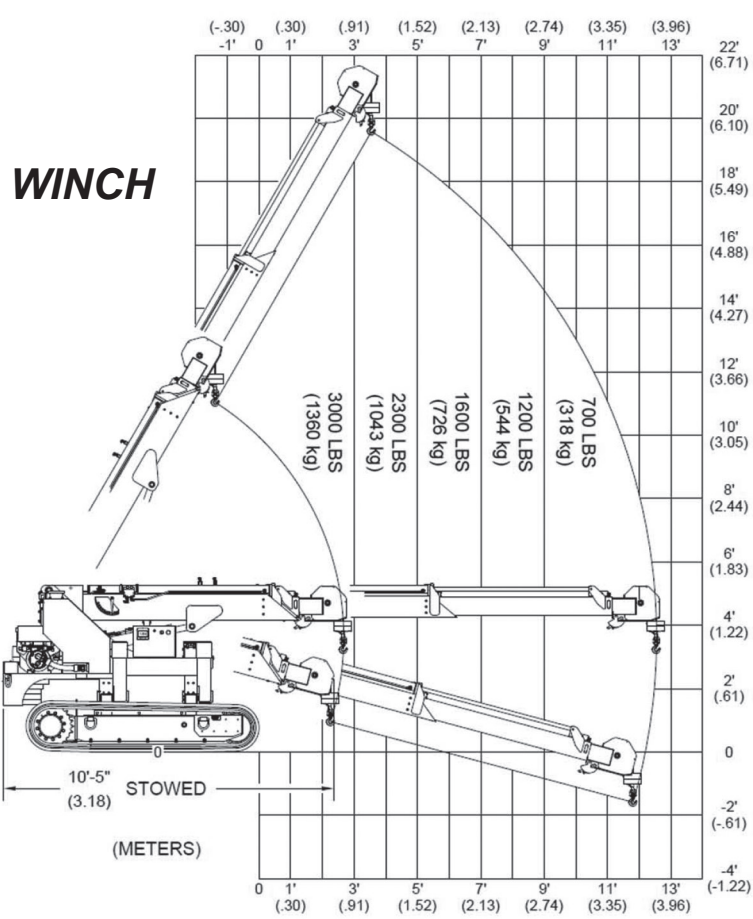
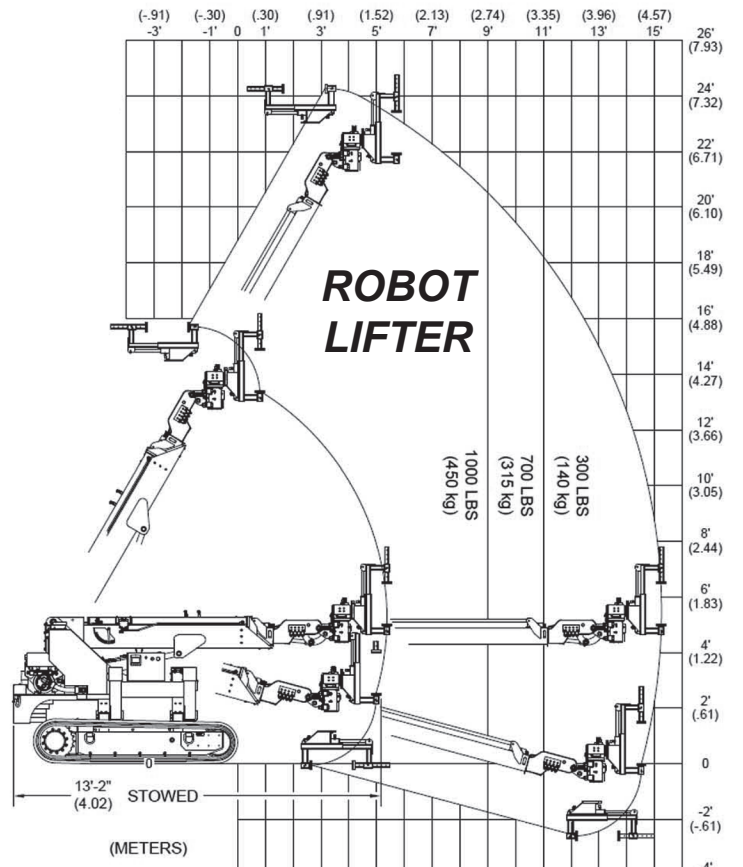
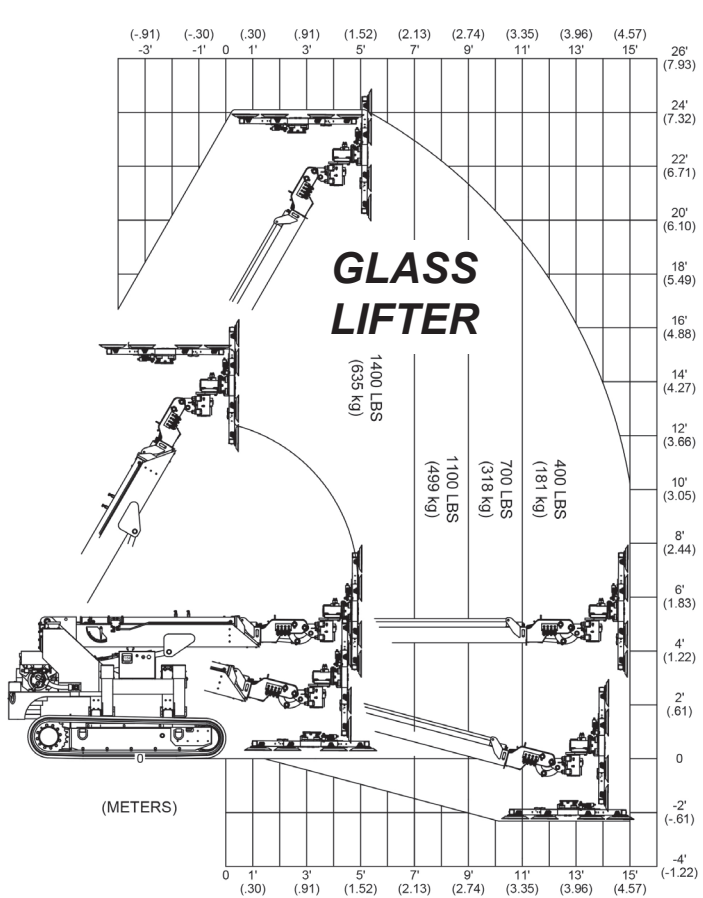

Features



Rated Load Limiter
Automatically detects attachment and adjusts loading parameters



Propane-powered Kohler PCH740 Power-unit

- 25 Net Horsepower
- Variable Speed Governor
- 3 Year Unlimited Hour Commercial Warranty
- 3 Year Manufacturer Warranty



Independently Adjustable Tracks
8" of Vertical Slope Adjustment

Multiple Attachments

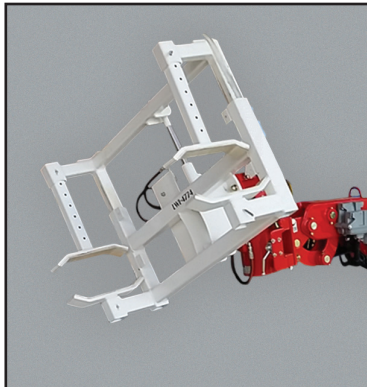

Robot



Man Basket



Hoist Winch



Forks



Glass



Hanging Glass

