

TL65 VERTICAL MAST LIFT



Features

- Omni-Motion Drive System
- High Capacity

Omni-Motion Drive System

Unique Omni-Motion Drive System provides machine movement in all directions and machine rotation around its center point.

- Increased productivity due to faster transport and positioning of the unit.
- Increased safety due to mobility of the unit into the optimal working position.
- Increased use due to the ability to reach working positions not possible to reach with conventional steering.

Options

- Clean Room Compatible
- Custom Platforms (Consult Factory)



TL50	US	Metric
Working Height (raised)	65 ft	19.8 m
Platform Capacity (unrestricted)	750 / 3000 lbs	341 / 1364 kg
Equipment Platform Size (nominal)	7 x 4 ft	2.1 m x 1.2 m
Man Platform Size (nominal)	6 x 2 ft	1.9 x 0.7 m
Stowed Height	18 ft 0 in	5.5 m
Stowed Length	9 ft 8 in	3 m
Overall Width (axle stowed)	8 ft 6 in	2.6 m
Tail Swing	0 in	0 in
Ground Clearance	3 in	7.6 cm
Turret Rotation	355° non-continuous	
Hydraulic Tank Capacity	80 gal	176 L
Gross Weight (estimated)	30,000 lbs	13,640 kg

Specifications Subject to Change Without Prior Notice.

Pendant Controls



Omni-Motion Drive System

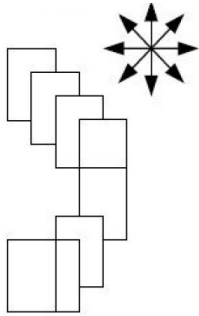

Omni-Motion

OMNI-Motion Drive System allows multi-directional motion for optimum positioning

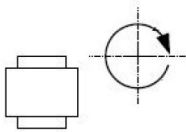

Spin

Spin capability allows machine to rotate about its center for tight maneuvering

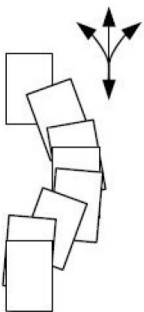

Standard Drive

Standard Drive Mode drives like an automobile for longer travel distances

TL65CR Vertical Mast Lift

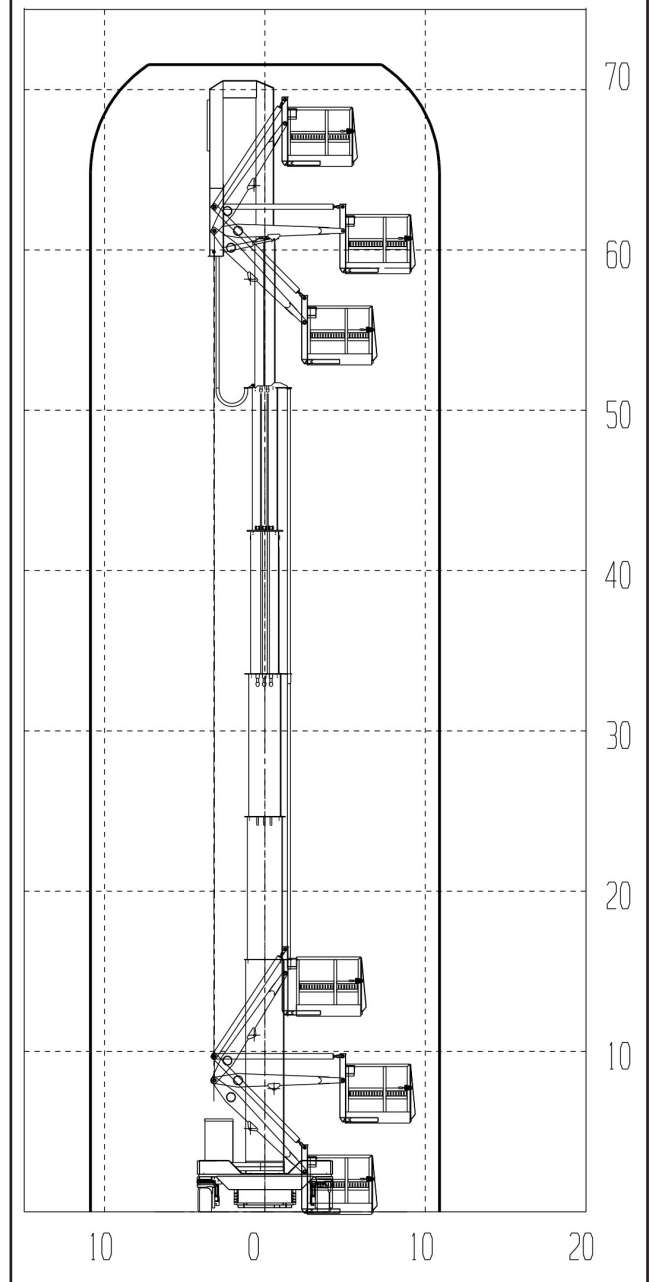

S81W18561 Gemini Drive, Muskego, WI 53150
262-710-4028 | www.BaileyCranes.com