

COAL MINING LIFT T25MH-2000

Manufactured to: MSHA 30 CFR 75.1909 | MSHA 30 CFR 75.1910



ANSUL A101 FIRE SUPPRESSION SYSTEM



PENDANT CONTROL FOR DRIVE / STEER

Features:

- 76" Low Stowed Height
- Uneven Terrain Oscillating Axle
- 2000 lb Platform Capacity
- Foam Filled Tires
- Removable Side Covers
- Hydrostatic Drive

Options:

- Stabilizers for Operation on Slopes up to 10 Degrees

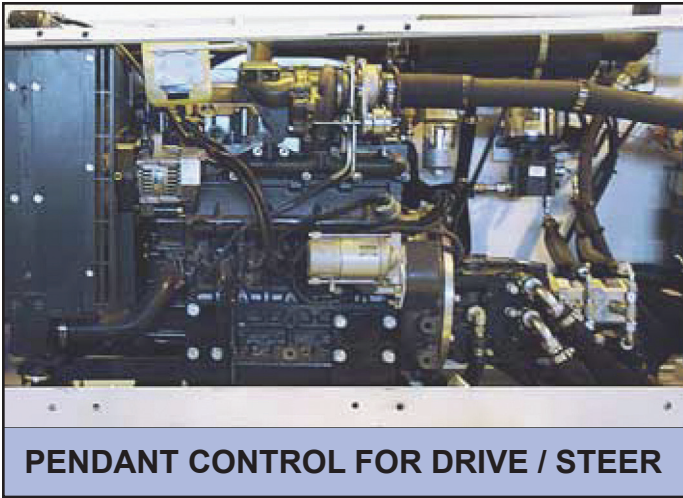

PENDANT CONTROL FOR DRIVE / STEER

Dimensions & Load Range Diagram:

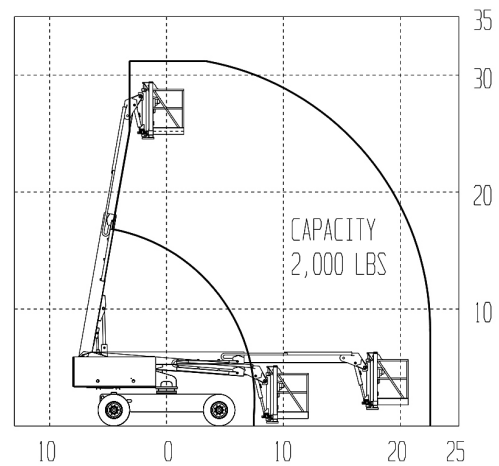
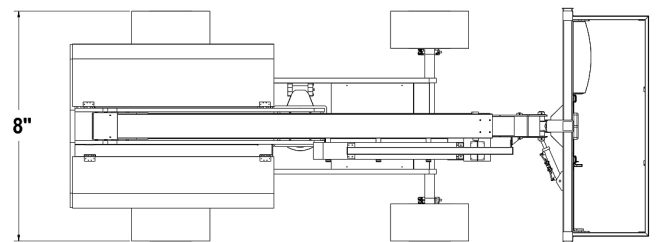
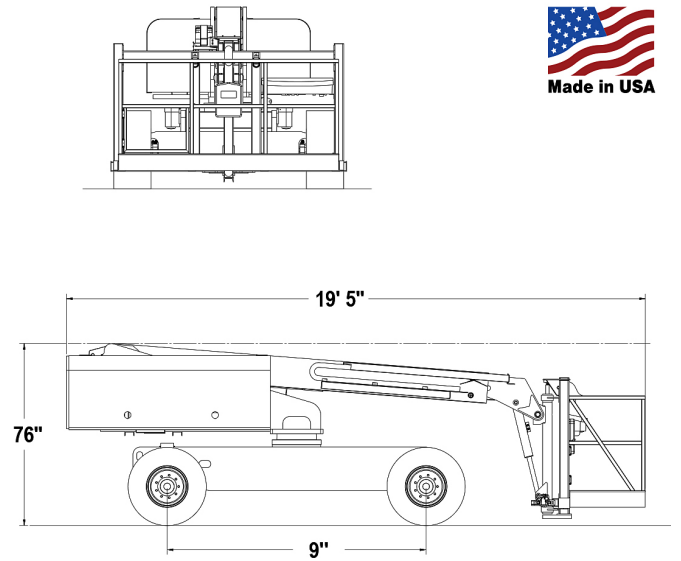

Specifications:

T25MH-2000	US	Metric
Working Height	31 ft	9.45 m
Platform Height	25 ft	7.62 m
Platform Capacity	2,000 lbs	907.18 kg
Platform Size	48 x 96 in	1.22 x 2.44 m
Stowed Height	76 in	1.93 m
Stowed Length	19 ft 5 in	5.94 m
Horizontal Reach	20 ft	6.10 m
Overall Width	8 ft	2.44 m
Tail Swing	3 ft 11 in	1.19 m
Outside Turning Radius	18 ft 1 in	5.49 m
Inside Turning Radius	8 ft 1 in	2.44 m
Ground Clearance	10.5 in	.27 m
Turret Rotation	360° cont	
Platform Rotation	150°	
Engine Power	40 HP Diesel	
Hydraulic Tank Capacity	45 Gal	170.3 L
Fuel Tank Capacity	35 Gal	132.5 L
Wheel Base	9 ft	2.74 m
Gross Weight	20,000 lbs	9071.8 kg
Travel Speed	3.8 mph	6.12 kph
Gradeability (4WD)	30%	

*Specifications Subject to Change Without Prior Notice

